

The W-Type suits all applications where the booms of the conveyor are required to adjust in height at both ends.

The WTC has a telescopic main boom whilst the W20 and W26 have fixed length booms.

## W - type

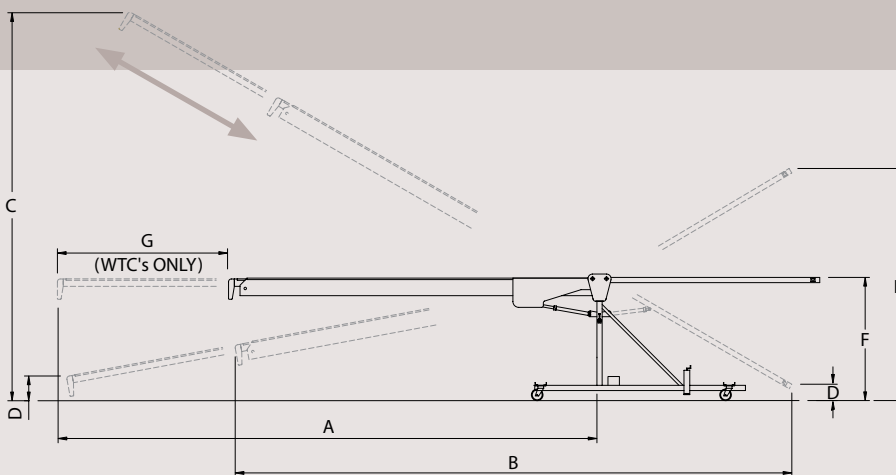

### General Dimensions (mm)

	W20	W26	WTC33	WTC38
<b>REACH INTO VEHICLE (A)</b>	6100	8000	10000	11550
<b>OVERALL LENGTH (B)</b>	9300	11200	9600	10350
<b>DELIVERY HEIGHT (C)</b>	5200	6100	7000	7800
<b>FEED HEIGHT (D)</b>	200	200	200	200
<b>DELIVERY HEIGHT (E)</b>	4000	4000	4000	4000
<b>POST HEIGHT (F)</b>	2100	2100	2100	2100
<b>TELESCOPIC ACTION (G)</b>	-	-	3685	4310

**Additional dimensions for all models:** Overall width at front wheels 1145mm. Overall width at delivery end 820mm. Overall width at belt power unit 1235mm.

# mobile

## Conveyors

### T - Type

The double hinged boom of the T-Type pivots on two sets of hydraulic rams to make the machine suitable for working from ground level or off a raised loading dock.

The TC/33, shown, has a telescopic boom for added flexibility and reach, while the T20 and T26 have a fixed length boom.

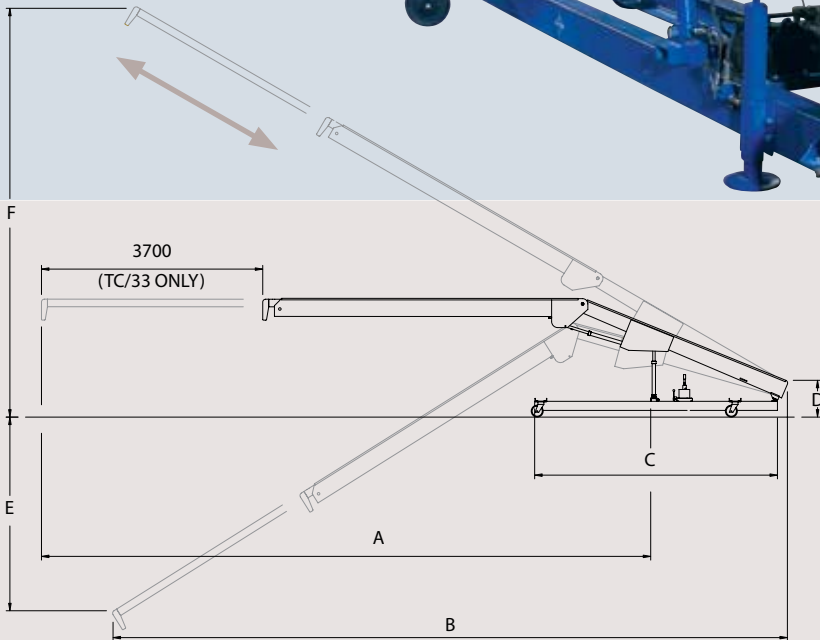
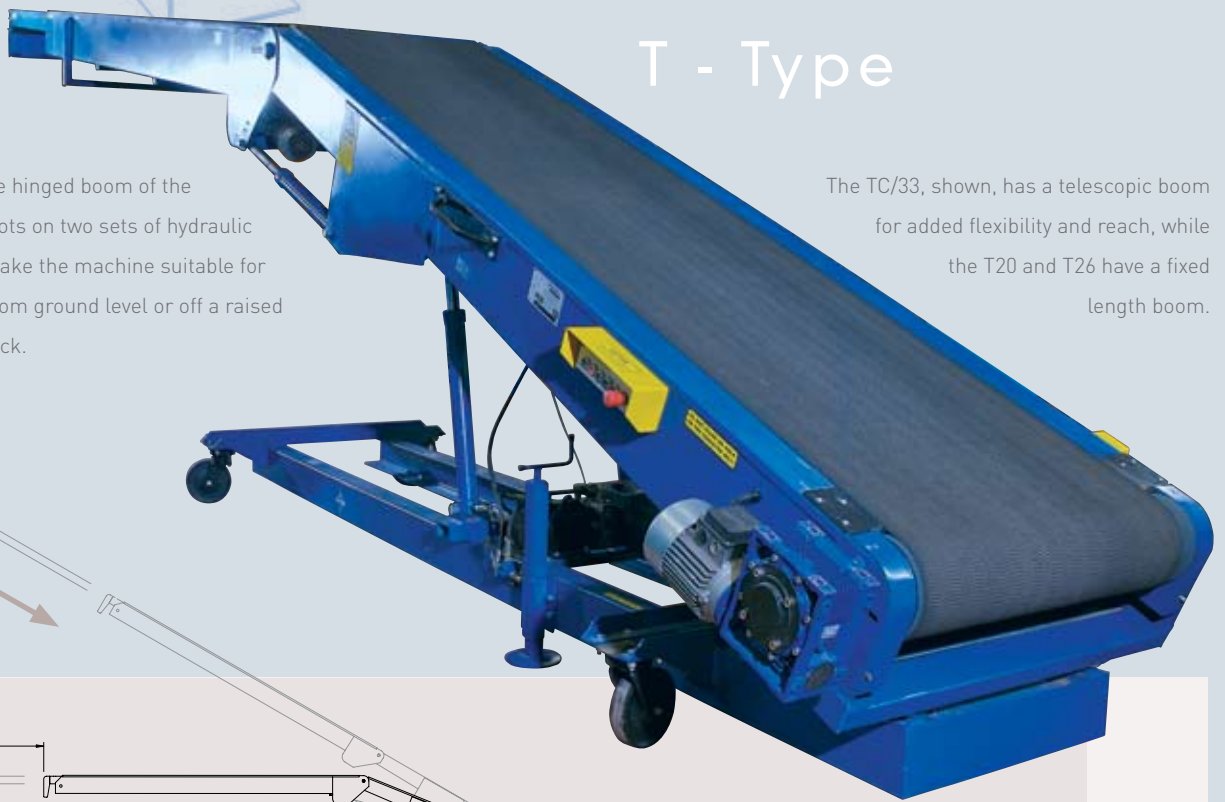

General Dimensions (mm)

	T20	T26	TC/33
<b>REACH INTO VEHICLE (A)</b>	6100	8000	10000
<b>MINIMUM LENGTH (B)</b>	8200	10000	8200
<b>CHASSIS LENGTH (C)</b>	3050	4060	4060
<b>LOADING HEIGHT (D)</b>	600	600	600
<b>MINIMUM DELIVERY HEIGHT BELOW GROUND LEVEL</b>	1300	2200	3500
<b>MAXIMUM DELIVERY HEIGHT</b>	4900	5800	6700

**Additional dimensions for all models:** Overall width at front wheels 1145mm. Overall width at delivery end 820mm. Overall width at belt power unit 1045mm.

# WS - type

The chain and slat conveyor is ideal for stacking and de-stacking sacks in warehouses and is also used for vehicle loading/unloading. The selected hardwood slats and precision conveyor chain make the machine ideal for harsh environments where only basic maintenance facilities exist.



# WS

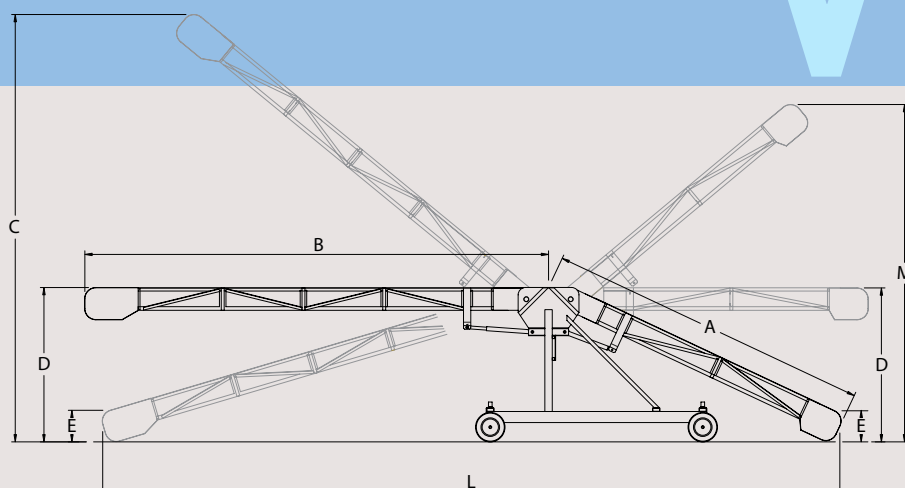

## General Dimensions (mm)

	WS12	WS20	WS26	WS30
<b>LENGTH OF SHORT BOOM (A)</b>	4110	4110	4110	4110
<b>LENGTH OF LONG BOOM (B)</b>	3660	6100	7930	9150
<b>OVERALL LENGTH (L)</b>	7110	9780	11660	12880
<b>DELIVERY HEIGHT (C)</b>	4270	5790	7100	7980
<b>FEED HEIGHT (E)</b>	380	380	380	380
<b>DELIVERY HEIGHT (M)</b>	4570	4570	4570	4570
<b>POST HEIGHT (D)</b>	2120	2120	2120	2120

**Additional dimensions for all models:** Overall width at wheels 1500mm. Slat width 600mm. Alternative widths readily available.