

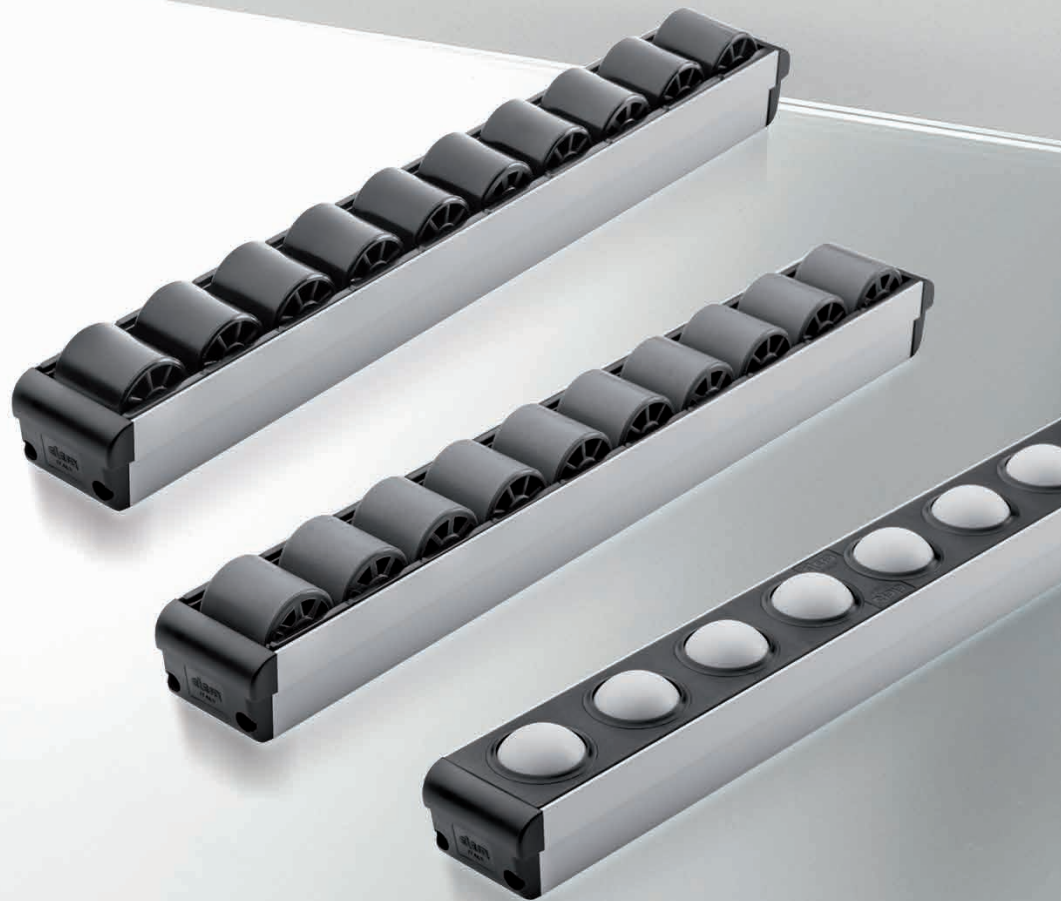

Modular roller tracks

ele:roll*



* Trademark application

Modular roller tracks for idle handling.

They can be used to create sliding and containing benches suitable for several applications in different fields: feeding and discharging benches in construction machinery, storage and picking systems, packaging machinery, etc.

Modularity

The roller track can be easily assembled by fixing the roller or ball elements inside the appropriate aluminium anodised profiles.

The particular section of the profile allows the snap-in assembly of the roller and ball elements into the profile without the need for screws or other fasteners.

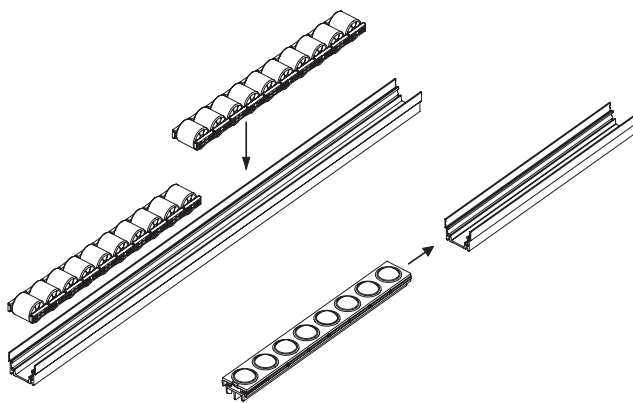

Substitution

The roller and ball elements may be removed and replaced quickly and easily, without disassembling the entire roller track.

The aluminium profile can be reused.

Sliding and quiet operation

The features of the materials of the rollers / balls and relative holders allow friction to be minimized and there is no need for lubrication maintenance.

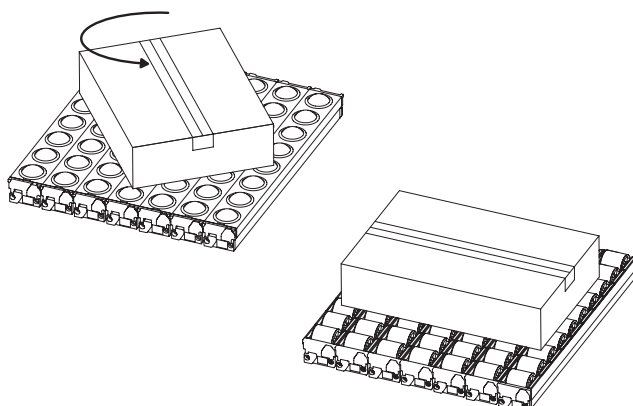

High load capacity

The roller track ensures a high load capacity, thanks to a maximum capacity for single roller of 360N (PA rollers) and 150N (TPU rollers).

High impact strength

The roller elements are characterized by a high capacity to absorb shocks due to drop of material on the roller track.

Handling of delicate materials

The thermoplastic (TPU) polyurethane rollers, anti-scratch and anti-trace material, are also suitable for handling delicate materials such as glass and wood.

Omnidirectional handling

The technopolymer acetal resin based (POM) balls allow to handle the material easily in any direction.



RLT-U

Roller elements

Acetal resin based (POM) technopolymer roller holder, black colour.

RLT-U-PA: polyamide based (PA) technopolymer rollers, black colour.

RLT-U-TPU: thermoplastic (TPU) polyurethane rollers, hardness 92 Shore A, grey colour.

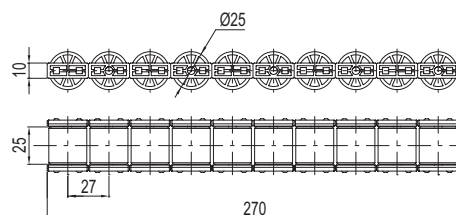

RLS-U

Ball elements

Balls: acetal resin based (POM) technopolymer, white colour.

Ball holder: polyamide based (PA) technopolymer, black colour.

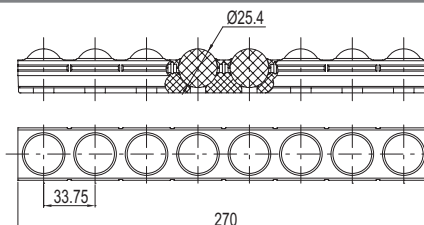

RLT-AL

Aluminium profiles

The profile can hold up to 11 RLT-U roller elements or RLS-U ball elements.

The profile ensures a high resistance to bending under load, and the assembly of the roller tracks without the need for other supports.

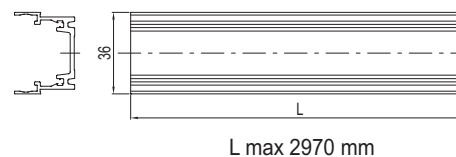

RLT-H

Headers

RLT-HJ header serves to bind tightly two rollers by engaging them. RLT-HE header is the end-element of roller tracks. In addition to being an aesthetic element, the headers represent a safety element for the operator's hands and the handled material.

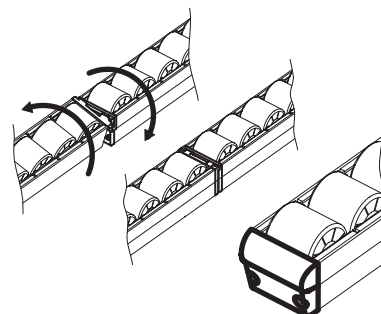

RLT-CE

Containment edge

RLT-CE containment edge is used for the lateral containment of products handled on roller tracks. It is snap-in assembled on RLT-AL aluminium profiles without the need for screws or other fasteners. It can also be mounted to the roller track already fixed.

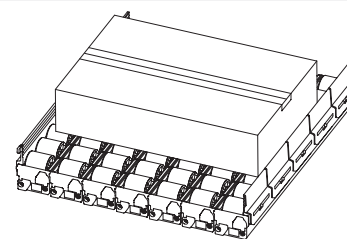

RLT-B

Brakes

RLT-B brakes allow to slow down and/or stop packages handled on roller tracks. The brakes are snap-in assembled on RLT-U roller elements without the need for screws or other fasteners.

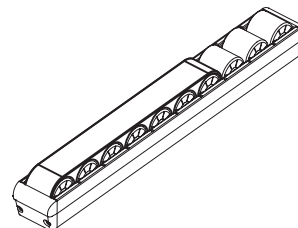

RLT-M

Bracket and support

The bracket and the support facilitate the mounting of roller tracks on machines and other supporting structures.

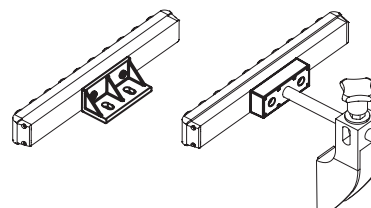

	Profile	Roller and ball elements	Load capacity #	
			Distributed load, roller fully supported 	Concentrated load on a single roller / ball
	RLT-AL	RLT-U-PA	13330 N/m	360 N
	RLT-AL	RLT-U-TPU	5550 N/m	150 N
	RLT-AL	RLS-U-POM	850 N/m	30 N

RLT-U-PA | RLT-U-TPU

Value of the load that produces an elastic deformation such as to prevent the regular rotation of the rollers, which come into contact with the ribs of the aluminum profile. At this value of load however, no permanent deformation of the material occurs.

RLS-U-POM

Load value that limits the smoothness of the balls inside its support, at low sliding speeds. At this value of load, however, no permanent deformation of the material occurs. For higher sliding speeds, it is necessary to refer to the chart at the side.

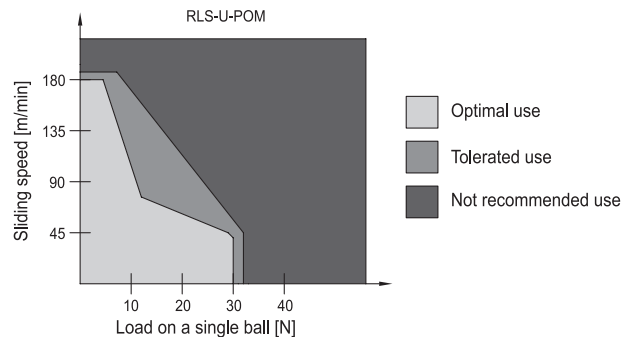

LOAD CAPACITY

LOAD CONCENTRATED IN THE CENTRE, ROLLER TRACK SUPPORTED IN TWO POINTS

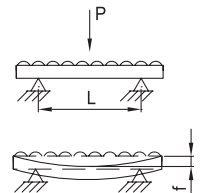
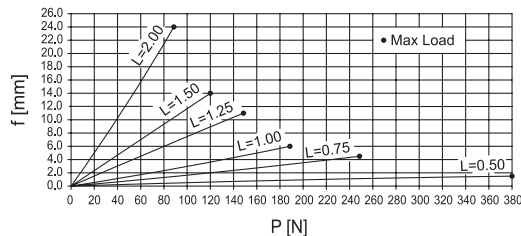
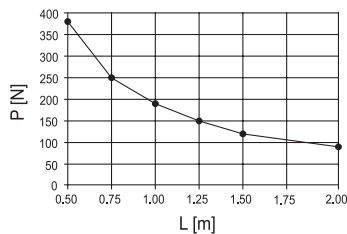

P: value of the load that, at the middle, generates an elastic deflection of the aluminum profile beyond which the product functionality may be compromised. At this value of load, however, no permanent deformation of the material occurs.

L = distance between supports.
f = arrow.

IMPACT STRENGTH

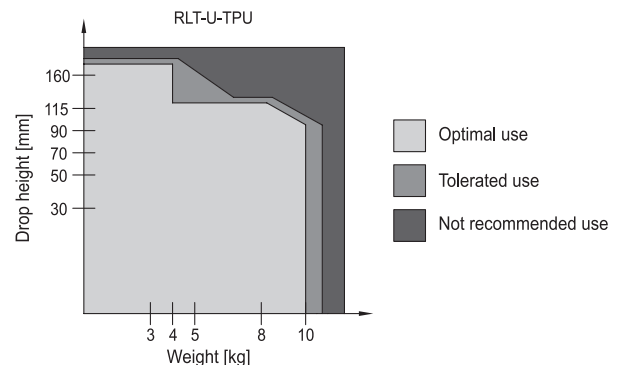
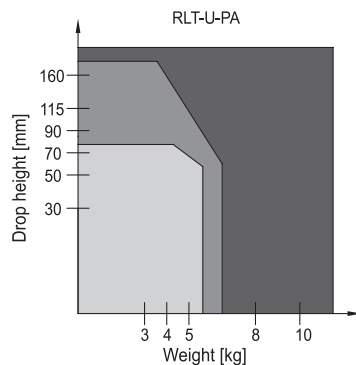

Roller elements for ELEROLL roller tracks



• Standard executions

- Acetal resin based (POM) technopolymer roller holder, black colour.
- **RLT-U-PA**: polyamide based (PA) technopolymer rollers, black colour. Working temperature +90°/-20°C.
- **RLT-U-TPU**: thermoplastic (TPU) polyurethane rollers, hardness 92 Shore A, grey colour. Working temperature +70°/-20°C.

Features and applications

- The roller elements, suitably fixed inside the RLT-AL aluminum profiles (Fig. 1) create modular roller tracks for idle handling (both as sliding or containing surfaces), suitable for several applications in different fields: feeding and discharging benches in construction machinery, storage and picking systems, packaging machinery, etc..
- RLT-U-PA roller elements are also suitable for handling heavy packages, RLT-U-TPU roller elements, with rollers in anti-scratch material, allow the handling of delicate materials such as glass and wood.
- The low friction coefficient between the roller and the roller holder eliminates the need for lubrication maintenance.
- The particular section of RLT-AL profile allows the snap-in assembly of the roller elements into the profile without the need for screws or other fasteners (Fig.1). Therefore the roller elements may be quickly and easily removed and replaced, without disassembling the entire roller track.
- The roller elements are divisible in correspondence of predefined sections (Fig.2) so as to create roller tracks of the precise required length.

Technical data

See: ELEROLL Modular roller tracks (page 2).

Special executions on request

Rollers in different colour (for example red, yellow, green for the setting up of assembly lines and dynamic warehouses according to Kanban criteria).

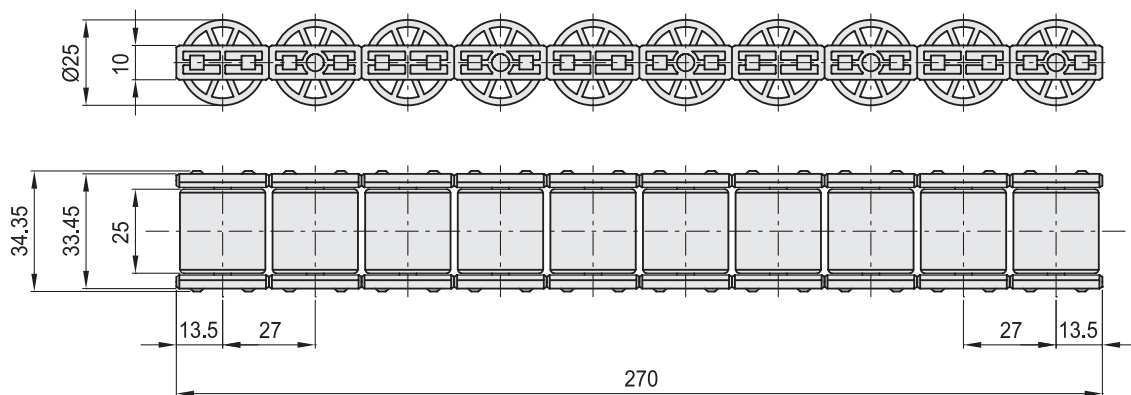
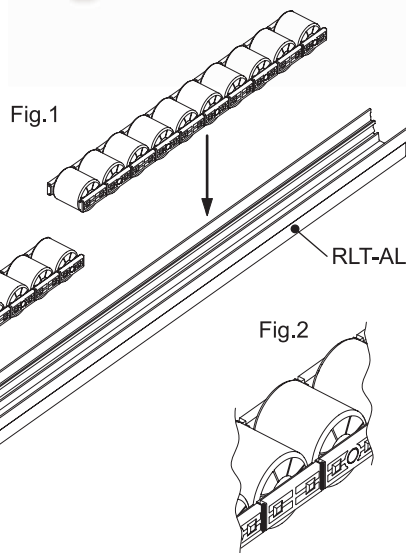

Standard Elements		⚖
Code	Description	g
429806	RLT-U-PA	106
429811	RLT-U-TPU	114

Ball elements for ELEROLL roller tracks



- **Balls**
Acetal resin based (POM) technopolymer, white colour.
- **Ball holder**
Polyamide based (PA) technopolymer, black colour.

Features and applications

- The ball elements, suitably fixed within the RLT-AL aluminum profiles (Fig. 1) create modular roller tracks for idle omnidirectional handling.
- The ball elements can be combined with RLT-U roller elements for various applications in different fields: feeding and discharging benches in construction machinery, storage and picking systems, packaging machinery, etc.
- The low friction coefficient between the ball and the ball holder eliminates the need for lubrication maintenance.
- The particular section of RLT-AL profile allows the snap-in assembly of the ball elements into the profile without the need for screws or other fasteners (Fig. 1).
- The ball elements are divisible in correspondence of predefined sections (Fig.2) so as to create roller tracks of the precise required length.
- The balls may be removed and replaced without disassembling the entire roller track, by using a common screwdriver in the appropriate notch cut into the ball holder (Fig. 3).

Technical data

See: ELEROLL Modular roller tracks (page 2).

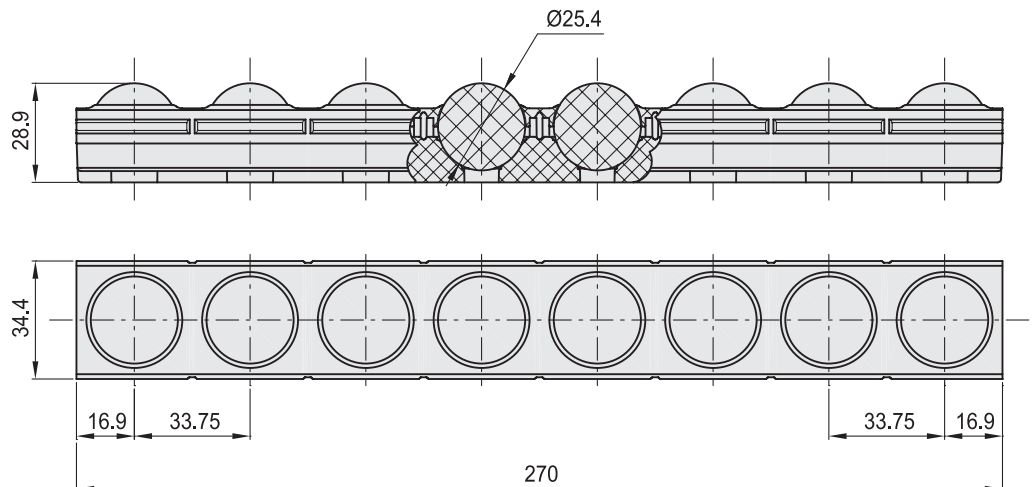
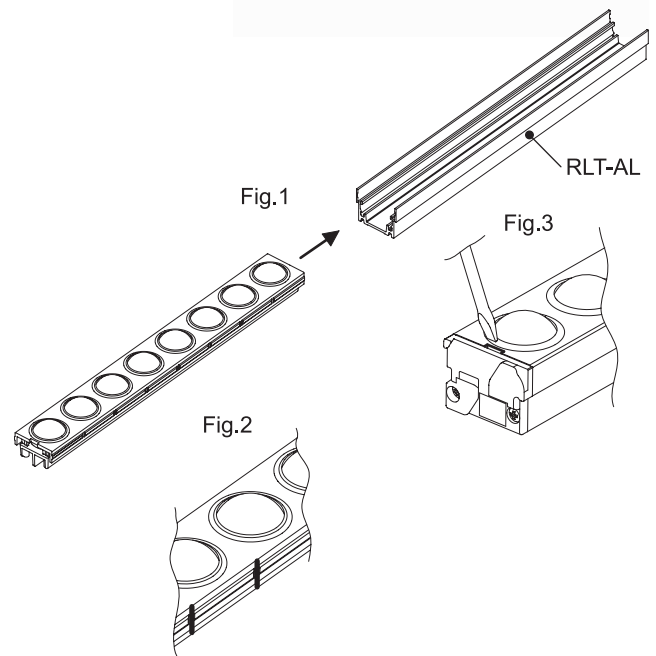

Standard Elements		⚖
Code	Description	g
429801	RLS-U-POM	151

Aluminium profiles for ELEROLL roller tracks



Material

Anodised aluminium, natural colour.

Features and applications

The profile can hold up to 11 RLT-U roller elements or RLS-U ball elements. The particular section of the profile allows the snap-in assembly of the roller and ball elements without the need for screws or other fasteners.

The profile ensures a high resistance to bending under load even in cases of point support (Fig. 1).

Special executions on request

Profiles with length different from the standard executions (maximum length 2970 mm).

Assembly instructions

Fix the profile to the supporting structure with screws of suitable size and number for the specific application, by making appropriate holes in the base of the profile.

The profile can be mounted in two points of support (Fig.1) or in complete support (Fig.2).

For the drainage of any fluids that can collect inside the profile (for example in case of applications on machines and equipment whose parts must be frequently cleaned by using water jets, for hygienic reasons) it is recommended to make holes of appropriate size and shape in the base of the profile.

Technical data

See: ELEROLL Modular roller tracks (page 2).

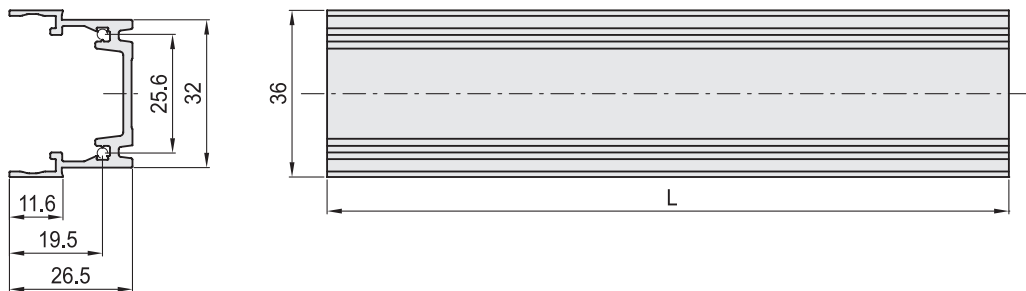
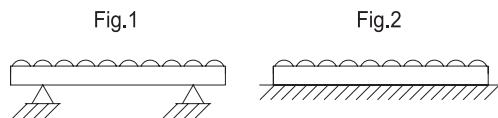

Standard Elements		Main dimensions	⚖
Code	Description	L	g
429900-0270	RLT-AL-270	270	123
429900-0540	RLT-AL-540	540	247
429900-0810	RLT-AL-810	810	370
429900-1080	RLT-AL-1080	1080	495
429900-1350	RLT-AL-1350	1350	618
429900-1620	RLT-AL-1620	1620	740
429900-1890	RLT-AL-1890	1890	865
429900-2160	RLT-AL-2160	2160	990
429900-2430	RLT-AL-2430	2430	1110
429900-2700	RLT-AL-2700	2700	1235
429900-2970	RLT-AL-2970	2970	1360

* Trademark application

ELESA and GANTER models all rights reserved in accordance with the law. Always mention the source when reproducing our drawings.

Headers for ELEROLL roller tracks



- **Material**
Polyamide based (PA) technopolymer, black colour.
- **Standard executions**
 - **RLT-HJ**: joining header.
 - **RLT-HE**: end header.

Features and applications

RLT-HJ header serves to bind tightly two ELEROLL rollers by engaging them (Fig. 1).

RLT-HE header is the end-element of ELEROLL roller tracks (Fig. 2).

In addition to being an aesthetic element, the headers represent a safety element for the operator's hands and the handled material.

Assembly

Assemble the headers to the end of RLT-AL aluminum profile by means of two UNI 6954 Ø 2,9 x 13 self-tapping screws (not supplied).



Modular roller tracks

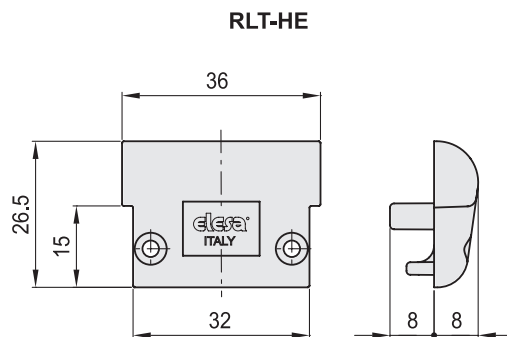
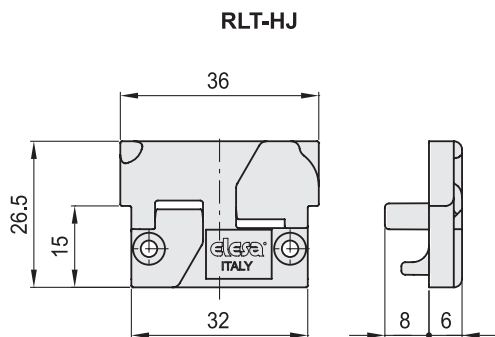
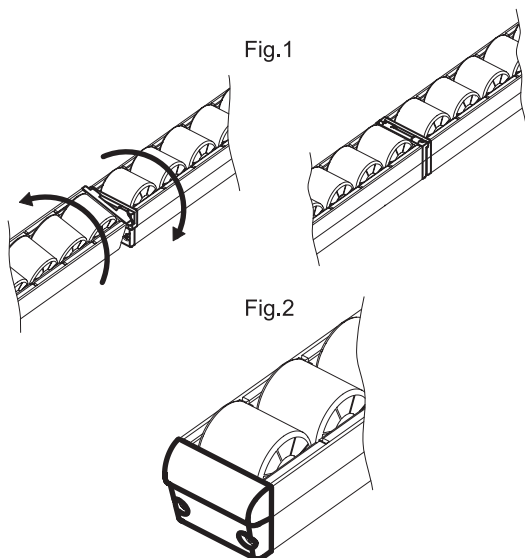

Standard Elements		⚖
Code	Description	g
429816	RLT-HJ	4
429821	RLT-HE	6

Containment edge for ELEROLL roller tracks

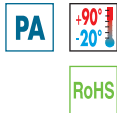

Material

Polyamide based (PA) technopolymer, black colour.

Features and applications

Realized to be used with RLT-U roller elements, RLT-CE containment edge needs for the lateral containment of light products handled on ELEROLL roller tracks (Fig. 1).

For the containment of medium-heavy materials refer to the RLT-M series (Fig. 3).

The edge is snap-in assembled on RLT-AL aluminum profiles without the need for screws or other fasteners (Fig. 2). It can also be mounted to the roller track already fixed.



Fig.1

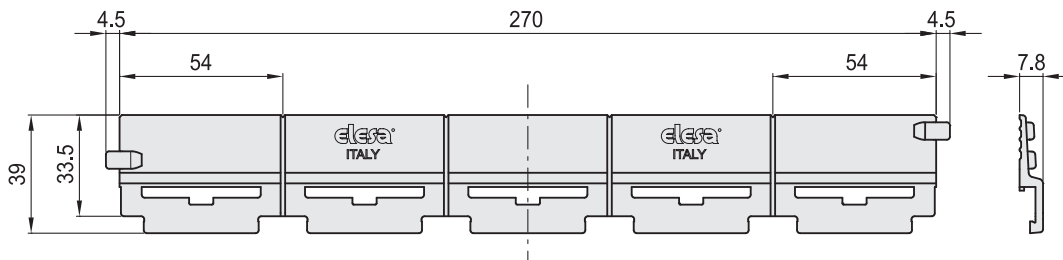
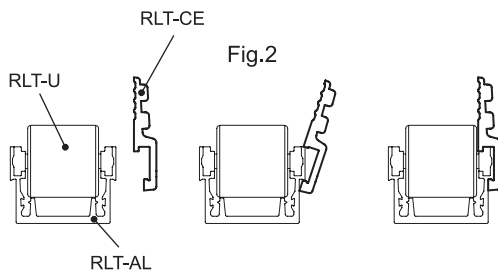
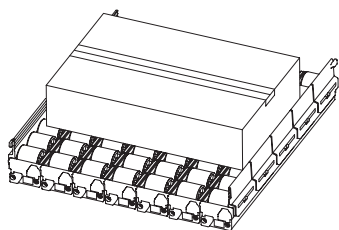

Standard Elements		⚖
Code	Description	g
429826	RLT-CE	34

* Trademark application

ELESA and GANTER models all rights reserved in accordance with the law. Always mention the source when reproducing our drawings.

RLT-B

FM Design

ele:roll*

Brakes for ELEROLL roller tracks

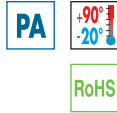

Material

Polyamide based (PA) technopolymer, black colour.

Standard executions

- **RLT-BR**: brake for RLT-U roller elements.
- **RLT-BRS**: brake for RLT-U roller elements with stop device.

Features and applications

RLT-B brakes allow to slow down and/or stop packages handled on ELEROLL roller tracks.

The brakes are snap-in assembled on RLT-U roller elements without the need for screws or other fasteners.

RLT-BR brake can be assembled on the upper side of RLT-U-PA and RLT-U-TPU roller elements (Fig. 1) or on the lower side of the RLT-U-TPU roller elements (Fig. 2).



Fig.1

Fig.2

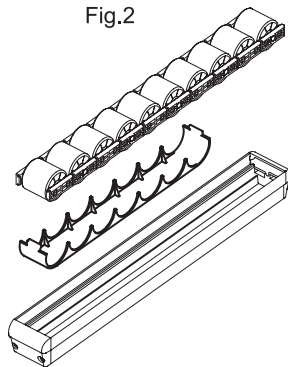
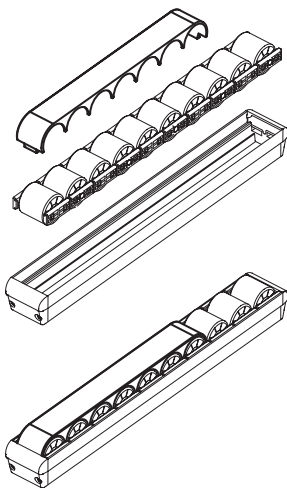

RLT-BR

RLT-BRS

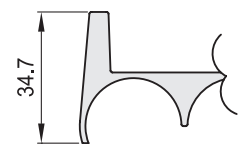
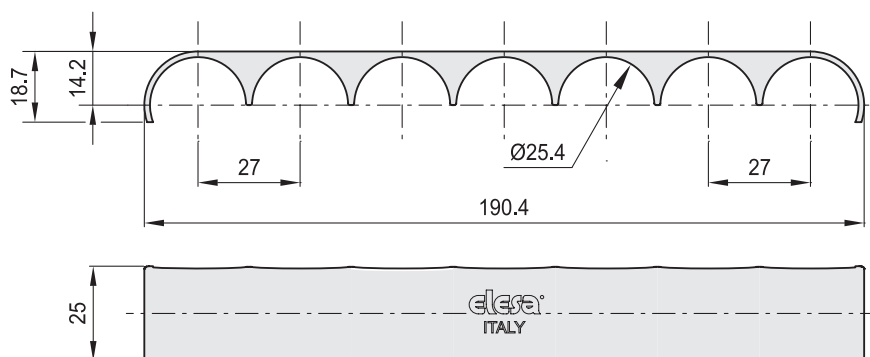

Standard Elements		⚖
Code	Description	g
429836	RLT-BR	12
429831	RLT-BRS	14

Bracket and support for ELEROLL roller tracks

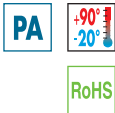

Material

Polyamide based (PA) technopolymer, black colour.

Standard executions

- **RLT-MB**: bracket.
- **RLT-MS**: support.
- **RLT-MS-A12**: support with connecting rod and M6 cylindrical head screw with hexagon socket.

Features and applications

The bracket and the support facilitate the mounting of ELEROLL roller tracks on machines and other supporting structures.

Assembly

The bracket and the support are equipped with dowels that are housed in the slots in the lower side of RLT-AL aluminum profiles (Fig. 1) and in special counterseats on the same support for the combination of more supporting elements (Fig. 2). RLT-MB bracket is compatible with profiles having a slot of 8 mm width (Fig.4). The bracket and the support allow to mount ELEROLL roller tracks in different configurations. Some examples are shown in Fig.1, Fig.2 and Fig.3.

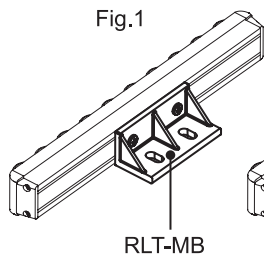

RLT-MB

RLT-MB

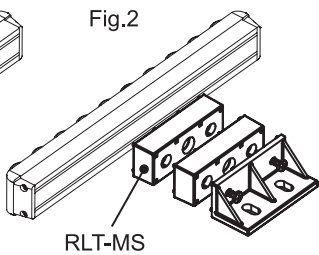

RLT-MS

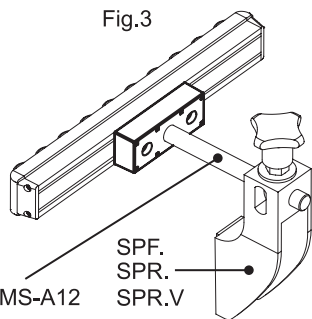

SPF.
SPR.
SPR.V

RLT-MS

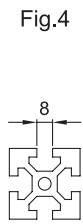
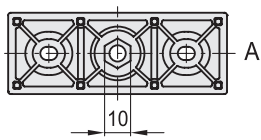
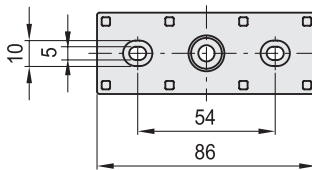
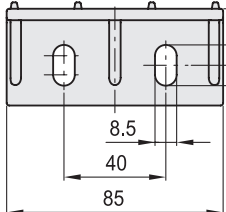
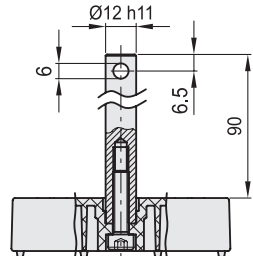
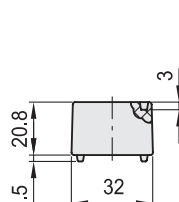
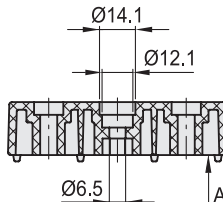
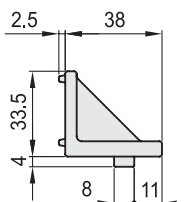
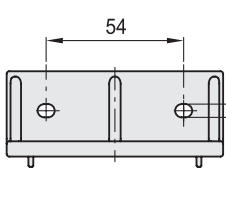

Fig.4

RLT-MS-A12



Standard Elements		⚖
Code	Description	g
429841	RLT-MB	35
429846	RLT-MS	49
429848	RLT-MS-A12	145

* Trademark application

ELESA and GANTER models all rights reserved in accordance with the law. Always mention the source when reproducing our drawings.

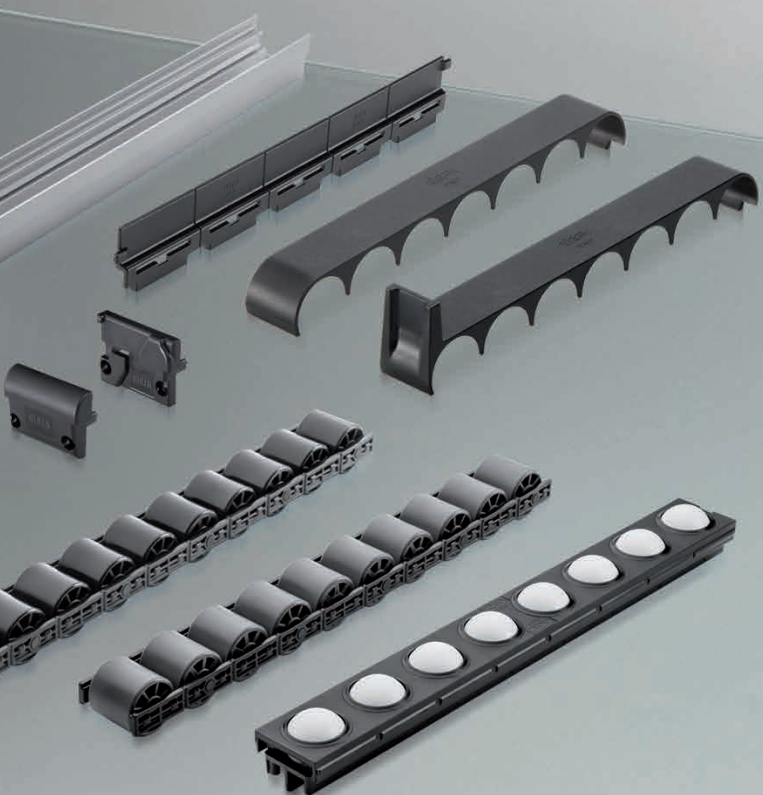

ELESA S.p.A.
Via Pompei 29
20900 Monza (MB) ITALY
Phone: +39 039 28 11.1
Fax: +39 039 83 63 51
www.elesa.com
info@elesa.com

OTTO GANTER GmbH & Co.KG
Triberger Straße 3
78120 Furtwangen GERMANY
Phone: +49 7723 65 07 130
Fax: +49 7723 65 07 165
www.ganter-griff.com
info@ganter-griff.de

www.elesa-ganter.com